



High Density Multiplexer Plug-in 1260-X138

Racal Instruments 1260-X138 is a high-density scanner/multiplexer switch card for use in a 1260-100X VXI Carrier.

This plug-in provides maximum flexibility to construct a wide range of scanner/multiplexer and matrix configurations under software control while maintaining excellent bandwidth and signal integrity.

All relays are bi-directional, enabling use as either a scanner or multiplexer. Each (1x8) multiplexer can be used to connect any combination of up to 8 two-wire signals to a two-wire common. These commons can be linked under program control to construct any combination of larger multiplexers. Possible configurations include:

- ◆ **Eight 1x8, Two-Wire Scanner/Multiplexer**
- ◆ **Software Configurable as a 2x24 Two-wire Matrix**
- ◆ **Link 1x8 Cells Under Program Control**
- ◆ **Link up to 6 Plug-Ins Under Program Control**
- ◆ **2-wire Design which is Ideal for Telecom and Datacom Applications**

- ◆ **One (1x64) two-wire**
- ◆ **Two (1x32) two-wire**
- ◆ **Four (1x16) two-wire**
- ◆ **One (1x16) two-wire plus One (1x48) two-wire**

On-board configuration relays allow six (1x8) multiplexers to be configured in to a 2x24 two-wire matrix. This saves using multiple cards to perform matrix and multiplexer functions.

Multiple plug-ins can be linked under program control via the X-series Adapt-a-Switch® carrier analog bus to form large two-wire multiplexers. This allows the user to construct very large multiplexers without external wiring. This eases the integration and wiring tasks while maintaining signal integrity.

This card was designed for two-wire operation, which makes it ideal for telecom and datacom applications.

With its combination of density, versatility, expandability, and excellent signal integrity, the 1260-X138 is ideal for constructing large switching systems. The 1260-X138 is an excellent choice for continuity, audio, video, telecom, datacom, and ATE systems testing.

When used with the 1260-100X Adapt-a-Switch® platform, an Option 01T is required to communicate with any set of switch cards. The Option 01T provides message-based operation for ease-of-use and register-based operation for maximum speeds.

An IVI-COM driver is available for this module.

1260-X138 PRODUCT SPECIFICATIONS

INPUT PERFORMANCE

Maximum Switching Voltage
300 VDC/AC (Pollution Class 1)
Maximum Switching Current
2 ADC, 2 AAC
Maximum Switching Power
60 W, 62.5 VA

DC PERFORMANCE

Path Resistance
1x8 (2-wire): < 1 Ω (Initial)
1x8 (2-wire): < 2 Ω (EOL)
Insulation Resistance
>10⁹ Ω
Thermal EMF
1x8 (2-wire): <10 μ V

AC PERFORMANCE (into 50 Ω)

Bandwidth (-3 dB)
1x8: < 40 MHz
Insertion Loss (1X8)
1 MHz: < 0.2 dB
10 MHz: < 0.6 dB
Isolation (1x8)
1 MHz: > 60 dB
10 MHz: > 45 dB
Crosstalk (1X8)
1 MHz: <- 60 dB
10 MHz: <- 50 dB
Capacitance
<80 pF

INTERFACE DATA

Cooling Requirements
See 1260-100X cooling data.
Maximum Overall Power Dissipation
60W
Power Requirements
+5 VDC at 900mA
+5VDC at 30 mA per energized relay

ENVIRONMENTAL DATA

Temperature
Operating: 0° C to 55° C
Non-operating: -40° C to 75° C
Relative Humidity
85% \pm 5%, non-condensing at <30° C
Altitude
Operating: 10,000 ft.*
Non-Operating: 15,000 ft.
Shock
30 g, 11 ms, 1/2 sine wave
Vibration
0.013 inch P-P, 5-55 Hz
Bench Handling
4-inch drop at 45°

EMC

Emissions
EN55011A with limits in accordance with EN50081-1.
Immunity
IEC901-2, 3, 4 with limits in accordance with EN50082-1

SAFETY**

EN61010-1
Impulse Withstand 1000 V

*Operation between 10,000 and 15,000 feet requires derating of maximum overall power dissipation to 49W.

** Certification Pending

RELIABILITY

Switching Time
<15ms
Rated Switch Operations
Mechanical: 1 x 10⁸
Electrical: 500,000 @ 30 V/1 A
MTBF
With relays 159,021 hours @25°C
With relays 142,422 hours @30°C
(50% rated load, 0.1 cycle/hour)

MECHANICAL

Weight
0.7 lb. (0.35 kg)
Dimensions
4.4" H X 0.75" W X 12.6" D
Front Panel Connector
160 pin DIN Connector

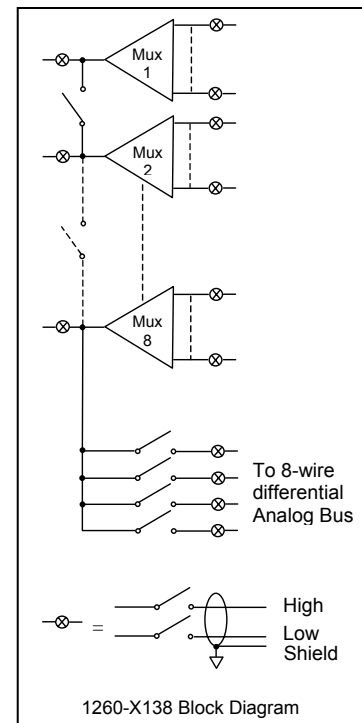

ORDERING INFORMATION

MODEL/DESCRIPTION

Racal Instruments 1260-X138 Adapt-a-Switch® High-Density Multiplexer Plug-in Module
160-pin Mating Connector, 160-pin Connector w/pins
160-pin Cable Assembly, 6ft., 24AWG

PART NUMBER

408010
407664
407408-001

The EADS North America Defense Test and Services policy is one of continuous development, consequently the equipment may vary in detail from the description and specification in this publication.



EADS North America Defense Test and Services
1.800.722.2528/1.949.859.8999 sales@eads-nadefense.com