



## RF Receiver & Signal Analyzer Model 2561



- 20-1200MHz Tuning Range with 10Hz Tuning Resolution
- High Dynamic Range:  
IP3: +10dBm typical  
NF: 10dB nominal
- Quadrature Digital IF Output (I&Q)
- Sweep or Scan up to 100 Channels per Second
- 17 Standard Bandwidths
- Phase-locked Local Oscillators for Multiple Channel Applications

The 2561 VHF/UHF Receiver is a high performance computer controlled 20 to 1200MHz single-slot C-sized VXIbus DSP receiver.

Systems requiring standard instrumentation can now include the latest in receiver technology. All of your VHF/UHF communication as well as Test & Measurement requirements are accomplished utilizing Digital Signal Processing (DSP) design for superior performance, higher reliability and lower cost.

### Signal Analyzer

In production ATE systems, where known frequencies need to be checked for spurious or harmonic content, the Model 2561 may be used as a signal level analyzer. The cost savings over a spectrum analyzer are significant.

### Automated RF Monitoring

Applications that require frequency occupancy or remote monitoring can now utilize up to 12 Model 2561's in a single mainframe. This "system" may be located in the back of a vehicle or

unmanned location. A program to control and gather data from the receivers can be built onto an embedded computer. The gathered data can be sent over the radio or land line to a central location.

### RF Applications

Applications include cellular radio frequency occupancy monitoring, propagation studies, direction finding and RF interference locating. This DSP receiver offers significant improvement over analog receivers.

These improvements include increased stability and precisely controlled filter characteristics which translates into greater reliability and performance.

**Flexible Scan and Sweep Modes**

Scan up to 250 pre-selected channels at a preset scan rate (up to 100 ch/s) and squelch level (ranging from 6 to 30dB). Sweep through up to 125 user-selectable bands setting dwell and bridge times of up to 9 seconds. Sweep step size may be specified and up to 100 frequencies may be skipped.

**Complex DSP Functions in Flash Memory**

Harness the power of DSP technology by loading the 2561's on-board flash with user-specified demodulation schemes, filtering or complex functions. Flash memory may be re-programmed any time over the VXIbus transforming the 2561 into a custom receiver for special applications.



Receiver Control Using VXIplug&play Software Front Panel

**2561 VHF/UHF Receiver Simplified Block Diagram**

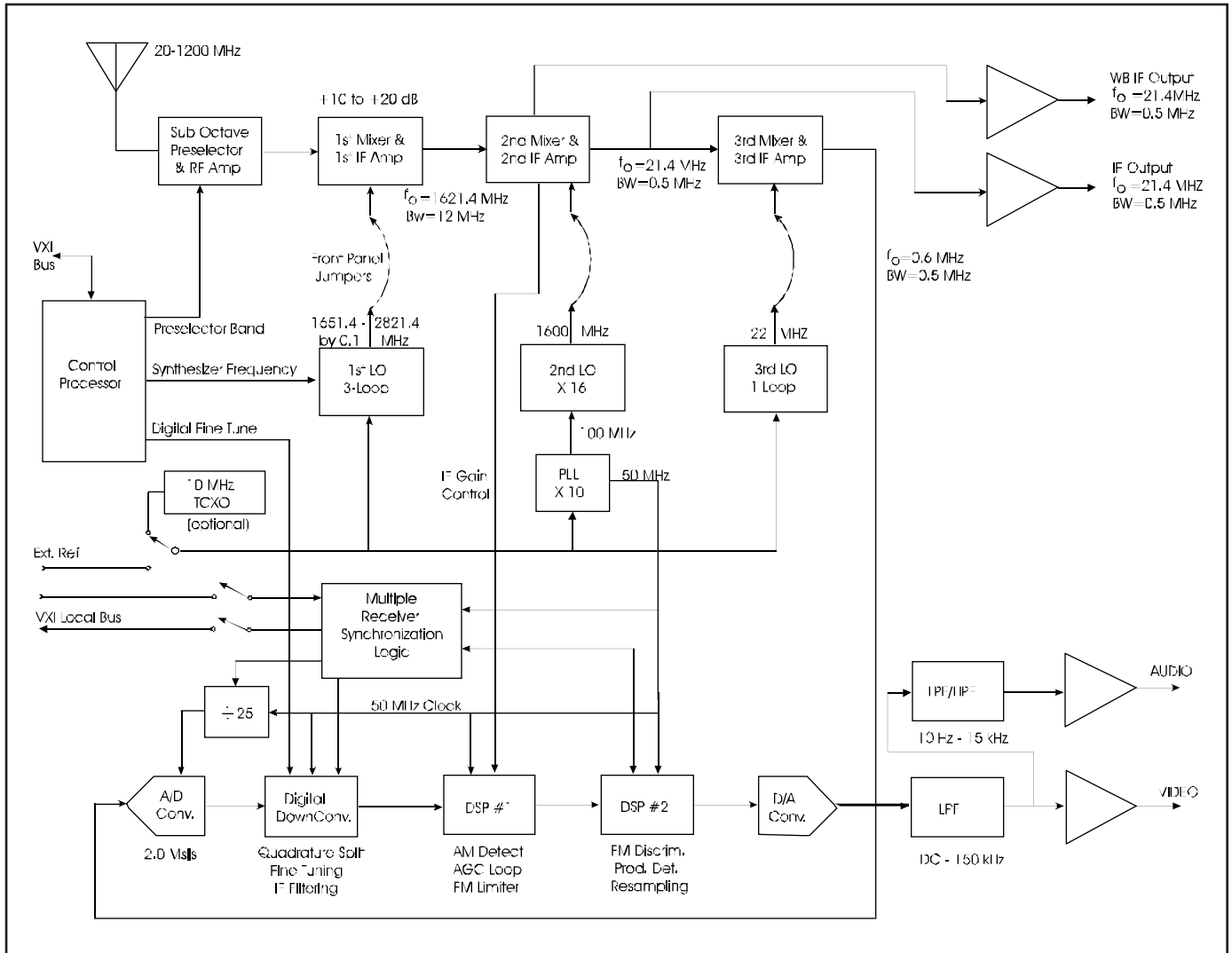

This 20-1200MHz receiver is a triple-conversion superheterodyne design in which the final IF filtering and demodulation are accomplished with DSP for superior accuracy and flexibility. The three intermediate frequencies (IF's) are 1621.4MHz, 21.4MHz, and 600kHz. Having the first IF above the entire tuning range assures spurious-free reception. At the third IF the signal is converted to digital form. Digital signal processor chips then provide fine tuning, IF filtering to the selected bandwidth, and AM, FM or product detection. Sixteen IF bandwidths are offered from 1kHz to 240kHz with video output up to 160kHz. The demodulated signals are converted back to analog form for output to a speaker, headphones or balanced lines.

# Model 2561 Specifications

## FREQUENCY

### Frequency Range

20 to 1200MHz

### Tuning Step Resolution

10Hz to 10MHz

### Synthesizer Tuning Speed

Range	Speed
$\Delta f < 100\text{kHz}$	0.7ms (typ)
$\Delta f < 50\text{MHz}$	1.2ms (typ)
$\Delta f < 500\text{MHz}$	2.4ms (typ)
20MHz to 100MHz	1.8ms (max)
100MHz to 599MHz	2.0ms (max)
600MHz to 1GHz	3.0ms (max)
across 600MHz	4.0ms (max)

### Receiver Tuning Time

<10ms

### Tuning Accuracy

External Frequency Standard (10MHz): Tuned frequency equal to accuracy of external standard in ppm.

## DETECTION MODES

### AM,FM

All bandwidths

### USB, LSB,CW

Bandwidths <15kHz

## SIGNAL LEVEL ANALYSIS

### Signal Level Range

-110dBm to -10dBm

### Signal Level Resolution

1dBm

## SQUELCH CONTROL

(Carrier-to-noise ratio for SCAN and SWEEP modes)

### Programmable Range

0 to 99dB (programmable)

### Resolution

1dB

## DWELL & BRIDGE

### CONTROL

#### Dwell Time

Time to "dwell" on a scanned channel or swept frequency when a signal strength exceeds the squelch threshold.

#### Dwell Time Range

0 to 9s

#### Bridge Time

If a scanned channel or swept frequency's signal strength drops below the squelch threshold during dwell, this is the amount of time the receiver waits for the signal to return before it leaves the channel.

#### Bridge Time Range

0 to 9s

## SCAN MODE

### Channel Presets

250

### Channel Parameters Stored

Frequency	Detection Mode	BW
De-emphasis	Squelch Value	BFO
Step Size	Dwell Time	AGC
AGC Decay	Bridge Time	MGC
Skip Flag		

### Scan Range

1 to 250 channels

### ScanRate

1 to 100 channels/s

## SWEEP MODE

### Sweep Types

Single-band: Sweep between 2 consecutive channels  
Multi-band: 2 to 125 sweep bands

### Sweep Frequency

1 to 100 channels/s

## RF SECTION

### RF Input Impedance (nominal)

50 $\Omega$

### RF Input VSWR

<1.5:1 (typical)  
<2.5:1 (maximum at tuned frequency)

### Sensitivity

AM (50% modulation, 50kHz BW):  
-101dBm for 10dB SINAD  
FM (15kHz deviation, 50kHz BW, 1kHz modulation):  
-102dBm for 20dB SINAD  
SSB (3kHz BW): -111dBm for 10dB SINAD

### Noise Figure (typical)

20-1000MHz: 12dB

### RF Input Protection

50 dB reflective attenuation. Activates at signal levels between +10dBm and +20 dBm. Protects from input signals up to 10 watts.

### RF Filters

A six-band preselector set consisting of the following bands:

Band	Frequency MHz
1	20-93
2	93-156
3	156-255
4	255-430
5	430-720
6	720-1200

## AUTOMATIC GAIN

### CONTROL (AGC)

#### Attack Time (50dB Change)

LSB,USB,CW: <10ms  
AM,FM: 50ms

#### Decay Time (50dB Change)

LSB, USB, CW: 0 to 4000ms (programmable)  
AM, FM: 50ms

#### Dynamic Range Accuracy

(Over 110dB range)  
 $\pm 1\text{dB}$

#### Threshold (nominal)

-110dBm

## MANUAL GAIN CONTROL (MGC)

### Dynamic Range

127dB

### MGC Resolution

1dB steps

## AUTOMATIC FREQUENCY

### CONTROL (AFC)

#### Tracking Range

IF bandwidth x 10

#### Acquisition Range

IF bandwidth  $\pm 50\%$

## IF SECTION

### First IF

1621.4MHz

### Second IF

214MHz

### Third IF

600kHz

### Fourth IF (DSP)

17 standard bandwidths: 1, 2, 3, 5, 6, 10, 15, 20, 25, 30, 35, 50, 60, 100, 150, 180, 240kHz

### Shape Factor (6dB - 80 dB)

Better than 1.5: 1

### Inband Ripple (max)

<1dB

## INTERFERENCE IMMUNITY

### IF Rejection

>90dB

### Image Rejection

>55dB

### Blocking

Attenuation of a desired RF signal of -60dBm by an unmodulated, undesired signal of -10dBm spaced 20MHz away is less than 3dB.

### Reciprocal Mixing (rated sensitivity, 50kHz BW)

An out of band signal 500kHz removed and 70dB higher in level will not degrade the (S+N)/N of the desired signal by >3dB.

# Model 2561 Specifications Continued

## INTERMODULATION AND DISTORTION

### 2nd Order Intercept

20-93MHz: +40dBm  
93-1200MHz: +60dBm

### 3rd Order Intercept (20-1200MHz)

+14dBm minimum (two equal  
-20dBm tones with 10MHz spacing)

### Inband

-50dBc (two equal -20dBm tones  
1kHz spacing)

### Synthesizer Phase Noise

1kHz offset: -77dBc/Hz  
10kHz offset: -81dBc/Hz  
100kHz offset: -95dBc/Hz

### Generated Spurious

No more than 5 at >-105dBm

### Oscillator Reradiation

<-100dBm

## FRONT PANEL INPUTS

### Antenna

SMA (20-1200MHz, 50Ω)

### 1st, 2nd, 3rd LO (jack)

Coaxial D-sub

### External Reference

SMB male: 10MHz, 0dBm, ±3dBm  
(50Ω)

## FRONT PANEL OUTPUTS

### Wideband IF (20dB gain, nominal)

SMA female ( $f_c=21.4\text{MHz}$ , BW=8MHz)

### Narrowband IF

(30dB gain @ <-10dBm output)  
SMA female, ( $f_c=21.4\text{MHz}$ ,  
BW=500kHz)

### 1st, 2nd, & 3rd LO (plug)

Coaxial D-sub

### Stereo Headphone Jack

1/8" connector: 8Ω

### DSP Signals (12-pin, female circular connector)

Line audio: 600Ω balanced (20Hz -  
15kHz)

Wideband Video: 600mV<sub>pk-pk</sub>, 75Ω  
(DC-160kHz)

Digital I&Q: TTL (serial, 12.5MHz)

## VXibus INTERFACE DATA

(single-slot, message-based VXibus 1.4 complaint)

### Drivers

LabVIEW, LabWindows/CVI,  
VXIplug&play (WIN, WIN 95, WIN NT  
Frameworks)

### Front Panel Indicator

Red LED: self-test failure

### Weight

6 lbs. (2.7kg)

### Peak Current & Power

#### Consumption

	+24	+12	+5	-5.2	-12
$I_{PM}$	0.5A	1.5A	1.5A	0.3A	0.3A

Total Power: <43 Watts

## ENVIRONMENTAL DATA

### Temperature Range

Operating: 0 °C to 50°C  
Storage: -40°C to +71°C

### Humidity

10 to 90% non-condensing

### Shock

MIL-STD-810E, Method 516.4,  
Procedure VI

### Vibration

MIL-STD-810E, Method 514.4,  
Procedure I, Category 9

### EMI

Equipment designed to intent of the  
applicable requirements of MIL-STD-  
461/462 as a guide.

### EMC (Council Directive 89/336/EEC)

CISPR11 Class A  
IEC 801-2, 3A

### Safety (Low Voltage Directive 73/23/EEC)

EN61010-1, IEC1010-1, UL3111-1,  
CSA22.2#1010

### MTBF (MIL-HDBK-217F, Naval Sheltered)

>11,000 hours

**CE** The CE Mark indicates that the product has completed and passed rigorous testing in the area of RF Emissions, Immunity to Electromagnetic Disturbances and complies with European electrical safety standards.

## ORDERING INFORMATION

Model	Description	Part Number
2561	VHF/UHF DSP Receiver	RVXI-3550



<http://www.racalinst.com>

